

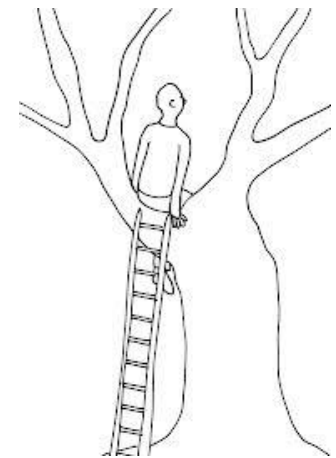

kwintes 

Bouwstenen voor sociaal
27 nov. 2013



Inhoud presentatie (oogpunt vastgoed)

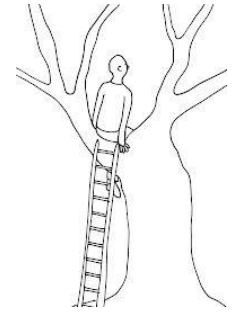

- Kwintes
 - Veranderende regelgeving
 - Vraagpunten
 - Voorlopige koers
-
- In gesprek

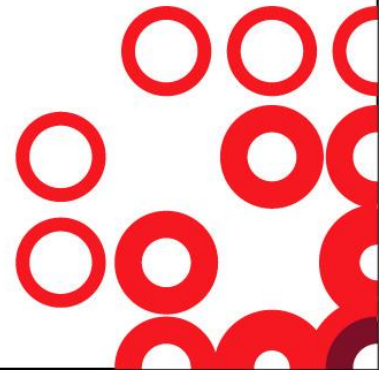

Kwintes

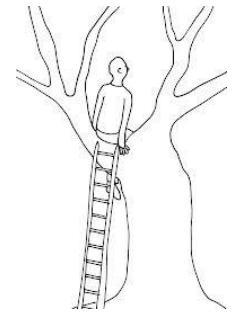

- RIBW & MO (wonen, activering, bureau herstel)
- AWBZ, gemeenten en justitie
- Ondersteuning met en zonder verblijf
- Volume (1.168 + 2.500)
- Geografisch (verspreid)
- Organisatie (zorg regionaal, vastgoed centraal georganiseerd)
- Eigendom versus huur (45% - 55%)

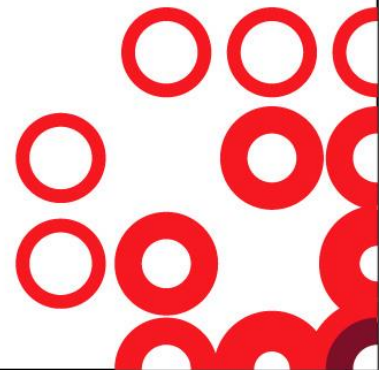

Veranderende regelgeving



Afbouw AWBZ meer betaalbare zorg



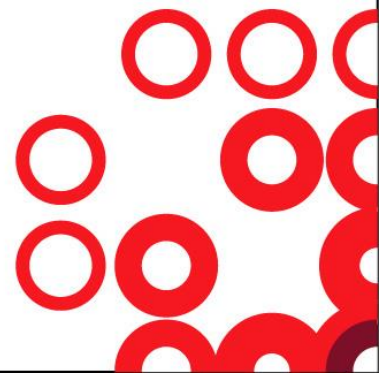
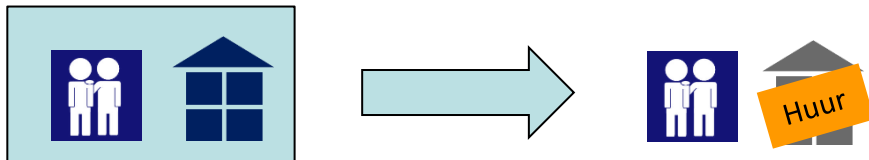





- Minder intramurale plaatsen meer ambulant
 - GGZ-zzp B segment naar Zvw
 - GGZ-zzp C segment (RIBW) naar Wmo
 - AWBZ ambulant naar de Wmo (-/- 25%)
-
- Uitwerking is nog niet duidelijk.
 - Scheiden wonen en zorg.....?











Veranderende regelgeving



Nu

- AWBZ ZZP B   
- AWBZ ZZP C  
- AWBZ Ambulant  
- Wmo Opvang  

Toekomst

- Zvw ~~ZZP B~~   
- Wmo ~~ZZP C~~  
- Wmo ~~Ambulant~~ (-/-25%)  
- Wmo Opvang  

Vraagpunten....



- Contracteren van 2 zorgkantoren naar 4(0) gemeenten
- Landelijk naar gemeentelijk beleid
- Afbouw bedden APZ is instroom RIBW (intensivering zorgzwaarte)
- Ontwikkeling van scheiden wonen en zorg....
 - AWBZ>WMO (zelf>sociaal netwerk>ondersteuning)
 - GGZ proces tegengesteld aan V&V,
 - Afbouw van beschermde woonlocaties....
 - Individueel verhuur
 - Leveringen SWZ ongelijk aan WWS
- Doorstroming naar regulier huur
- De problematiek van de woonsector raakt de zorgsector



Vraagpunten...



- Ingewikkeld
- Tevens mooie kans om te vernieuwen (wonen en zorg!)
- Complexiteit niet bagatelliseren!

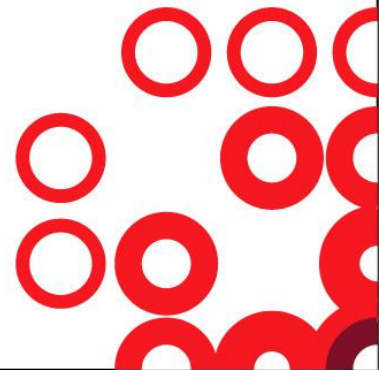

Voorlopige koers

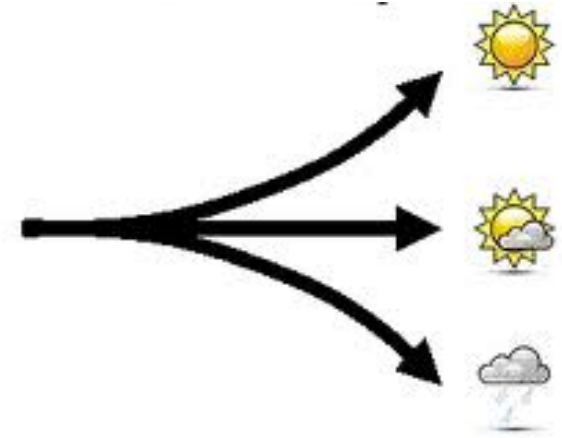

Scenario's/bandbreedte

1. Kwintes stopt met aanbieden van woonruimte (alleen begeleiding)
2. Kwintes gaat verhuren aan (deel van de) cliënten
3. Kwintes onderverhuurt voor WBC

Allerlei varianten op mogelijk

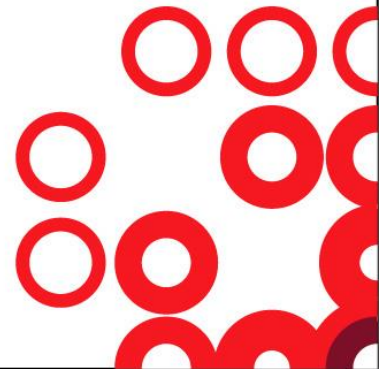

Voorlopige koers Kwintes



- Complexe begeleidings-/woonvraag
- Iedereen woont bij de woningbouwcorporatie tenzij.....
- Kwintes wil woonruimte blijven aanbieden voor kwetsbare mensen
- Binnen mogelijkheden huurder, wonen gericht op doorstroom.
- Innemen van een specifieke positie binnen de sociale huursector
- Duidelijk scheiding rollen ondersteuning en verhuren

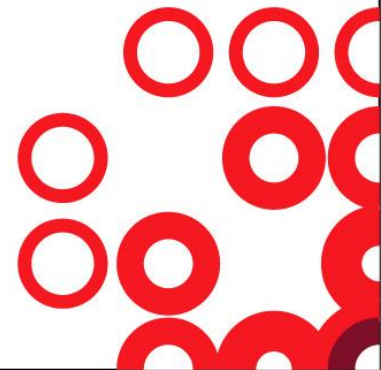

Voorlopige koers Kwintes

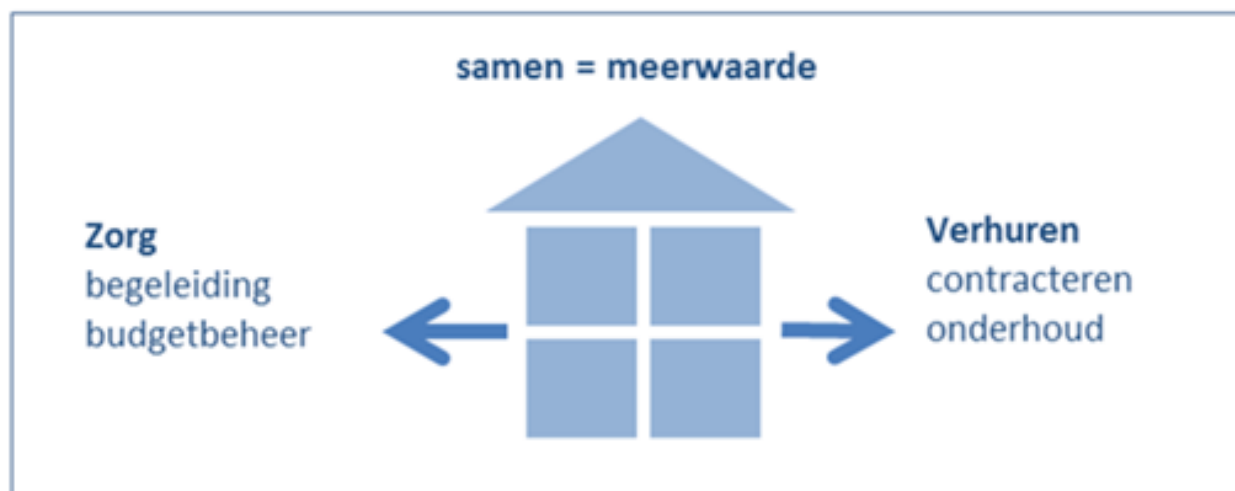

Voorlopige keuze

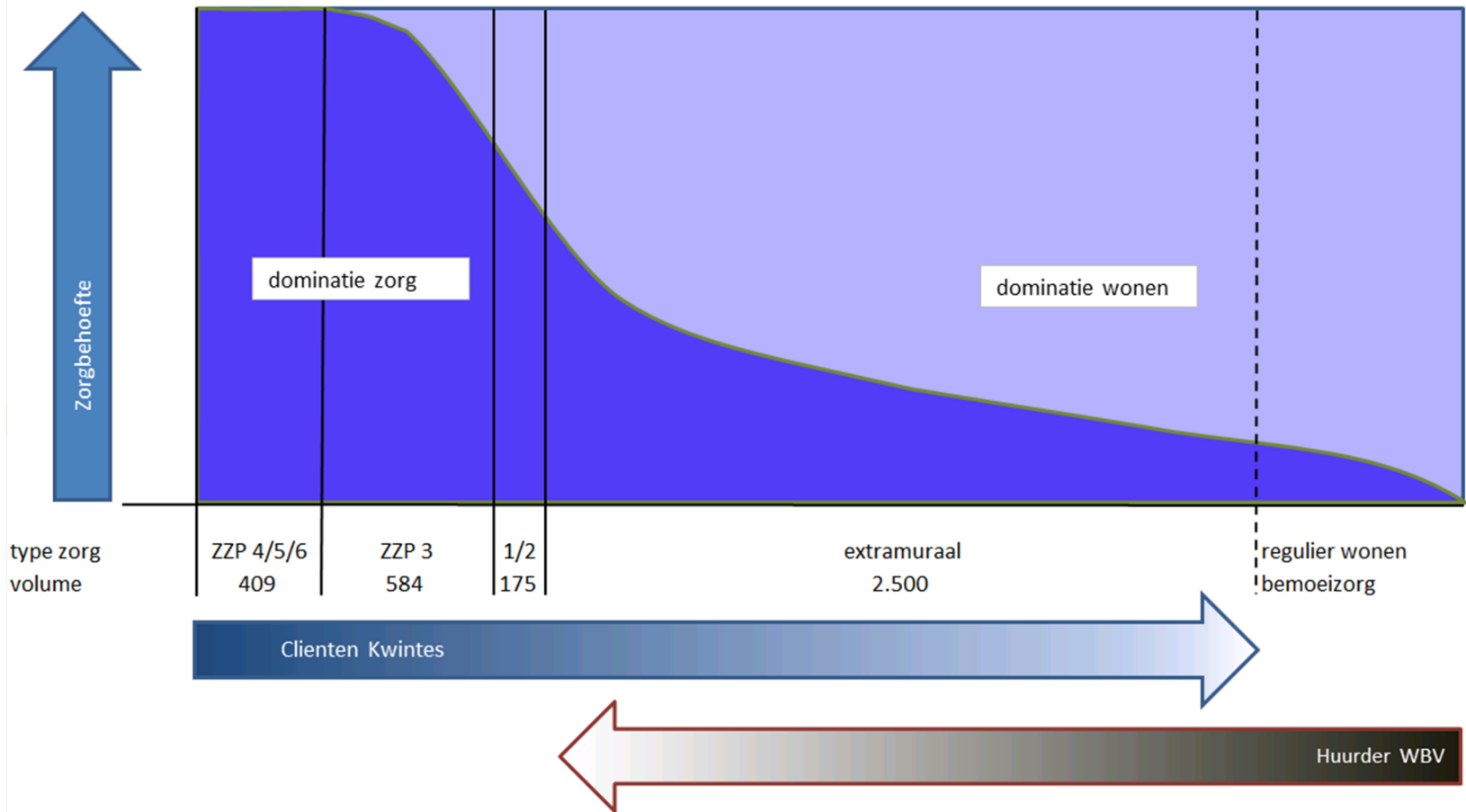

Voorlopige keuze

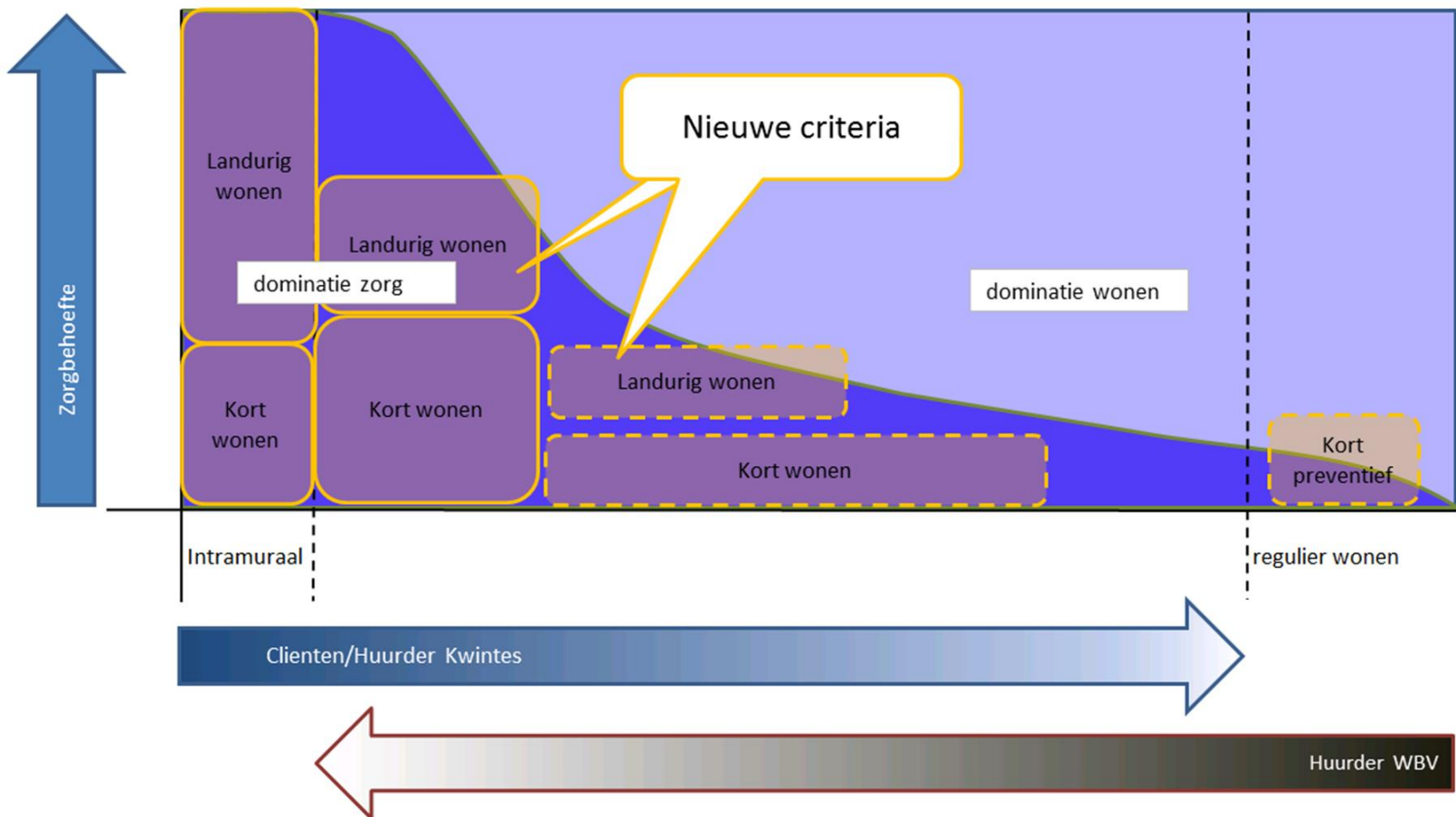

Kwintes (flexibiliteit)

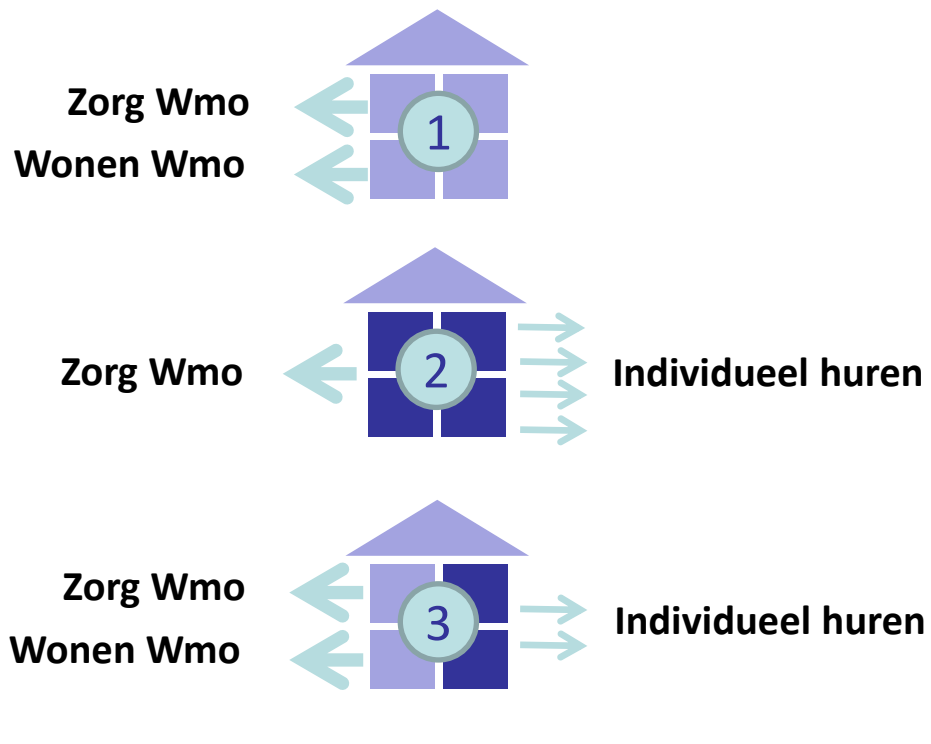

- Variatie per gemeente
- Variatie in tijd

Essentie...



Ingewikkeld, maar tevens mooie kans om te vernieuwen!
Onderscheidend woonproduct!
Kwetsbare mensen!



Gesprek



- Hoe wordt nu voorbereid op komst van psychiatrie naar gemeente
- Hoe zijn de ideeën m.b.t. scheiden van wonen en zorg (GGZ)



Einde of een begin...

